

**BERETTA BOBCAT & TOMCAT
EXCEPT 3032 TOMCAT INOX [STAINLESS] MODELS AND
ALL TOMCAT MODELS PRODUCED AFTER JANUARY 2010**

LG-490

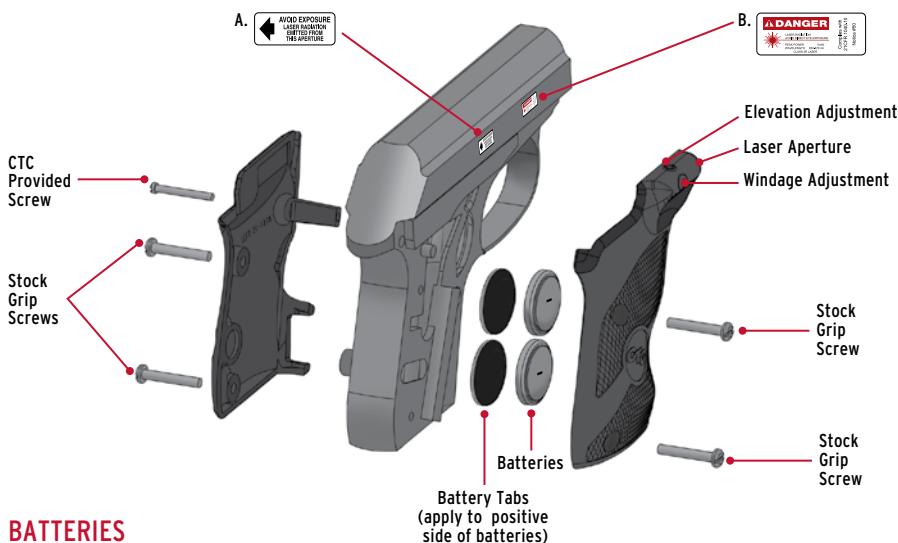

BATTERIES

Two (2) CR2032 or DL2032 Lithium Cells.

PRODUCT SPECIFICATIONS

BEAM INTENSITY: 5mW peak, 620-670 nm, Class 3R laser

DOT SIZE: Approximately 0.5 inches diameter at 50 feet

BATTERIES: Two #2032 lithium batteries;
over four hours of illumination

ACTIVATION: Front-located integrated momentary
pressure pad

WARRANTY: Three-year full warranty

This product complies with 21 CFR 1040.10

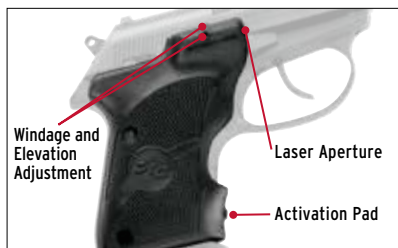

INSTALLATION INSTRUCTIONS

1. Make sure firearm is unloaded. Remove magazine and double check that chamber is empty. (See "Four Basic Rules Of Firearm Safety" in Owner's Handbook.)
2. Factory grips are held tightly in place and may need to be carefully pried from the frame. Take care when removing the stock grips from the right side of the firearm that you do not pull the safety away from the frame.
3. Place both batteries into the right hand grip panel positive (+) side up. Apply supplied adhesive battery tabs to positive (+) side of battery.
4. Place right-hand grip panel into position. Left hand grip panel must be rotated counter-clockwise into position in order for top right corner of grip to slide under safety lever. Do not overtighten the long, CTC-supplied screw or you will damage the grip.
5. Attach "Aperture" warning label with the arrow pointing to the laser aperture. Attach laser "Danger" sticker to outside of pistol.
6. Confirm that laser and iron sights are in alignment. Laser dot should rest on top of front site post with correct iron sight picture. Lasergrips are sighted-in at the factory to 50 feet, but can be fine-tuned to any point of impact by adjusting for windage and elevation. (See Laser Sight Owner's Handbook for complete sighting information.)

LASER SAFETY LABELING

IMPORTANT: LASER PRODUCTS MUST ONLY BE OPERATED WITH THE SAFETY LABEL APPLIED TO THE FIREARM.

Labels could not be affixed to the product but are supplied and must be installed as indicated below:

- A. Attach the "Aperture" warning label with the arrow pointing to the laser aperture.
- B. Attach the "Danger" warning label to the outside of the firearm.

Use caution when activating the laser to avoid direct eye exposure, which can result in permanent eye damage. Follow all precautions as outlined by the firearms manufacturer. Keep this and all firearm related products locked and secured from children or other unauthorized users.

NOTE: WILL NOT FIT STAINLESS OR INOX MODELS.

